

data SHEET

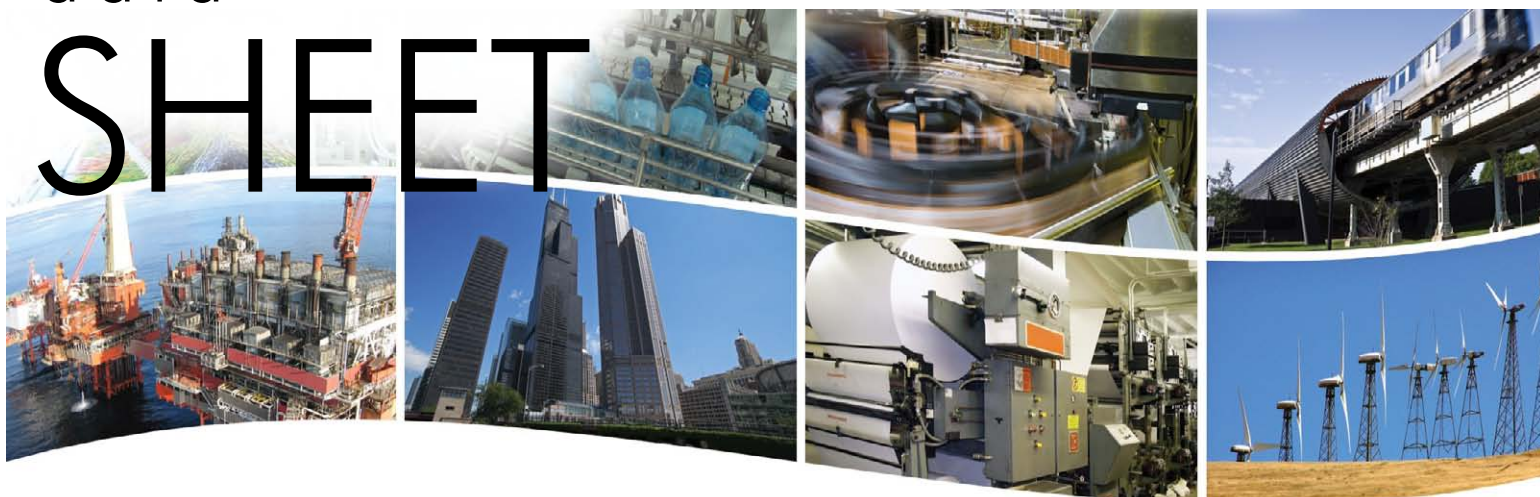

EIMK Industrial Ethernet Media Converters *Making the Copper to Fibre Connection*

The EIMK Skorpion Media Converter series makes the conversion of an Ethernet copper segment to fibre simple. By operating full-duplex at 100 Mbps provides the highest possible performance on 100 Mbps links. The EIMK is a true media converter and not just a two-port Ethernet switch. Therefore performance is enhanced by not introducing the store-and-forward data latency inherent in a switch. Both multimode and single-mode

models are available with ST or SC connectors. Fibre distances of up to 15 km are possible with the single-mode model — up to 2 km with the multimode models. On the copper side, both MDI and MDIX ports are available to compliment either an end station port or a switch port. Crossover functionality is accomplished on the fibre side by simply reversing fibre connections.

- Plug-and-Play operation
- 100BASE-TX/100BASE-FX conversion
- Shielded RJ-45 and SC/ST-style fibre optic connectors
- Full-duplex operation
- MDI and MDIX copper ports



- DIN-rail mounting
- Rugged metal enclosure
- Diagnostic LEDs
- Enhanced EMC compliance
- UL 508 listed, c-UL listed, CE mark
- 24 VAC/VDC powered

Overview

Each of the three models supports full-duplex operation for 100BASE-TX and 100BASE-FX segments. Two models support multimode fibre optic connections: the EIMK-100T/FT makes the fibre optic connection via ST-style connectors, whereas the EIMK-100T/FC does so via SC-style connectors. The model EIMK-100T/FCS supports single-mode fibre via SC-style connectors. Maximum distance with 62.5/125 µm multimode fibre cables is 2 km while single-mode fibre can span up to 15 km.

Two RJ-45 connectors (one MDIX port and one MDI port) allow either straight-through or crossover copper cabling. Link and activity

LEDs allow troubleshooting on both the copper and fibre sides.

All units mount on TS-35 DIN-rail and operate from either a 24 V AC or DC power source while offering redundant power connections. By incorporating a half-wave rectifier design, the sharing of the power source with other half-wave devices is possible.

Designed for commercial and industrial Ethernet applications, all models comply with EMC immunity and emissions compatibility standards for industrial environments.

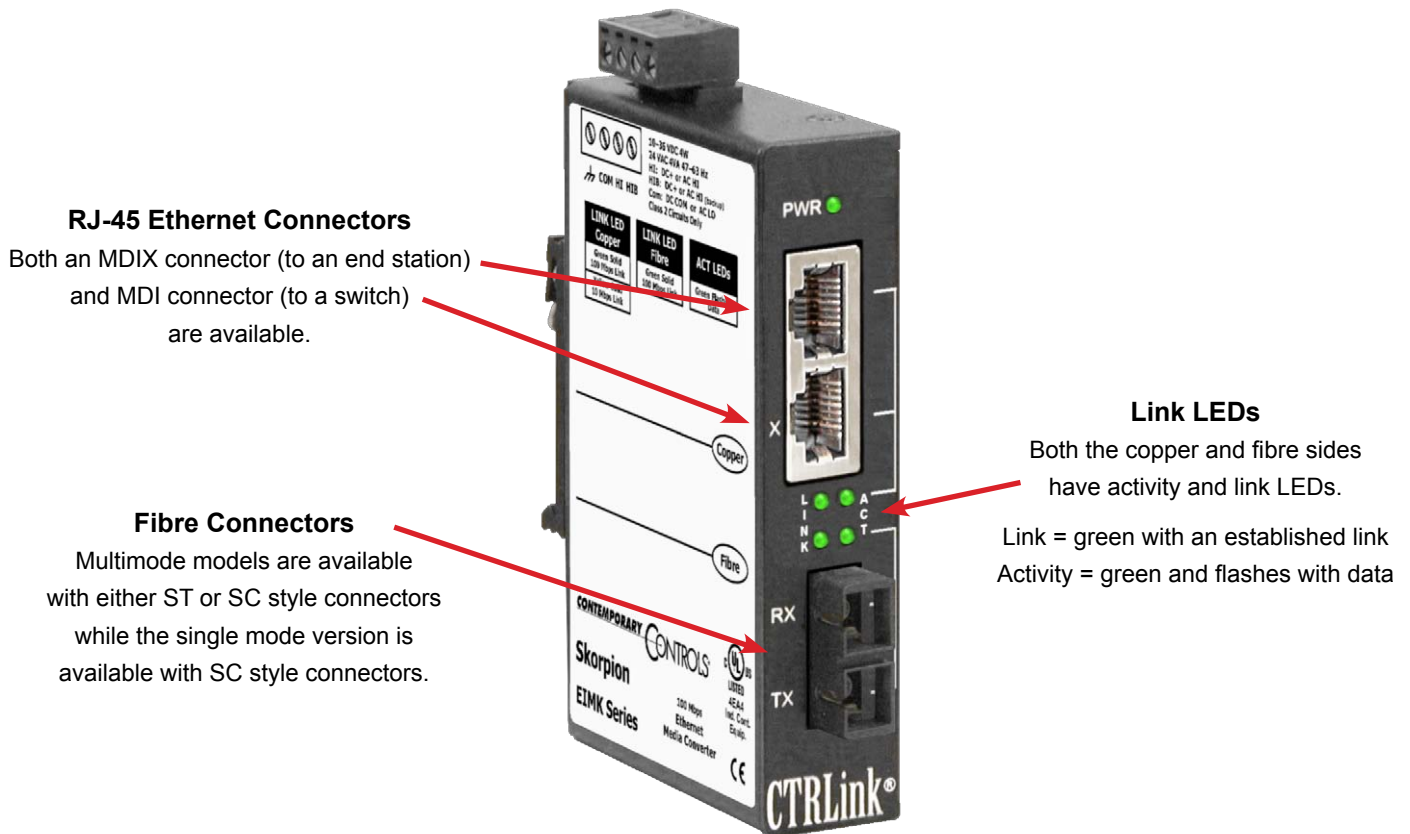

Specifications

Power Requirements	24 VDC $\pm 10\%$ 2 W or 24 VAC $\pm 10\%$ 4 VA 47–63 Hz						
Operating Temperature	0°C to 60°C						
Storage Temperature	–40°C to 85°C						
Relative Humidity	10–95%, non-condensing						
Protection	IP30						
Mounting	TS-35 DIN-rail						
Shipping Weight	1 lb (0.45 kg)						
Ethernet Communications	IEEE 802.3 100 Mbps data rate 100BASE-TX using RJ-45 connectors (MDI and MDIX), 100 m (max) 100BASE-FX multimode using SC or ST connectors, 2 km (max) 100BASE-FX single-mode using SC connectors, 15 km (max)						
LEDs	<table border="0"> <tr> <td>Power</td> <td>Green = power OK</td> </tr> <tr> <td>Link</td> <td>Green = communication established</td> </tr> <tr> <td>Activity</td> <td>Green = data transmissions occurring (flashes)</td> </tr> </table>	Power	Green = power OK	Link	Green = communication established	Activity	Green = data transmissions occurring (flashes)
Power	Green = power OK						
Link	Green = communication established						
Activity	Green = data transmissions occurring (flashes)						

Regulatory Compliance

CE Mark; CFR 47, Part 15 Class A; RoHS;
UL 508 Industrial Control Equipment



RJ-45 Connector Pin Assignments

Pin	Function
1	TD+
2	TD–
3	RD+
4	N/C
5	N/C
6	RD–
7	N/C
8	N/C

MDI and MDIX

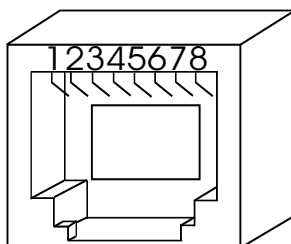

Mechanical Drawing

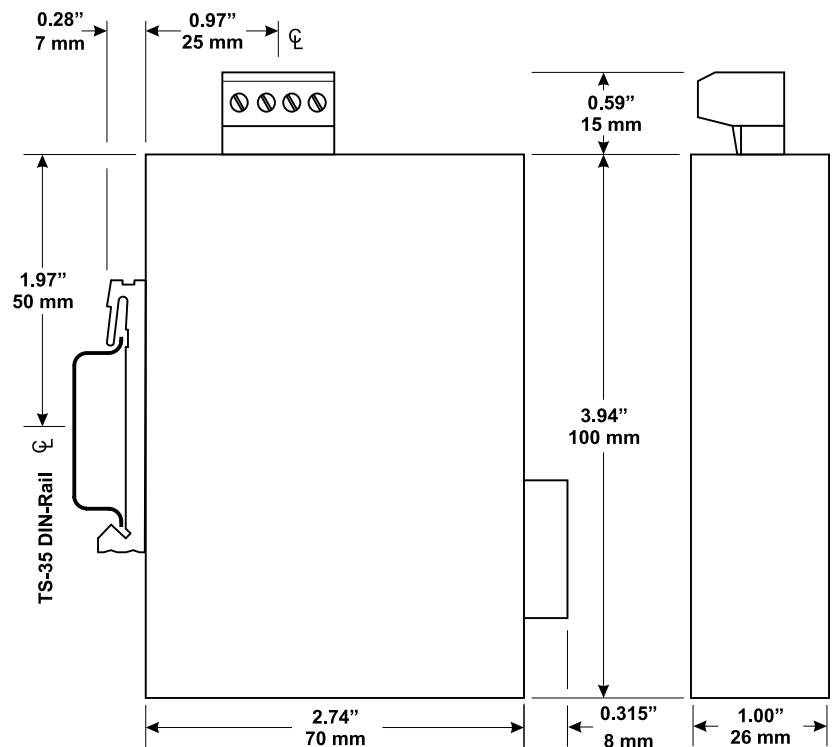

Power Considerations

Applied voltage must be in the range of 24 VAC/VDC $\pm 10\%$ and deliver a current commensurate with 4 VA power consumption. The recommended size for solid power conductors is 16–20 AWG; and for stranded conductors use 16–18 AWG. Zero volts (COM) is isolated from chassis (earth). Input connections are reverse-polarity protected.

Connecting chassis to earth or using a backup source is always optional.

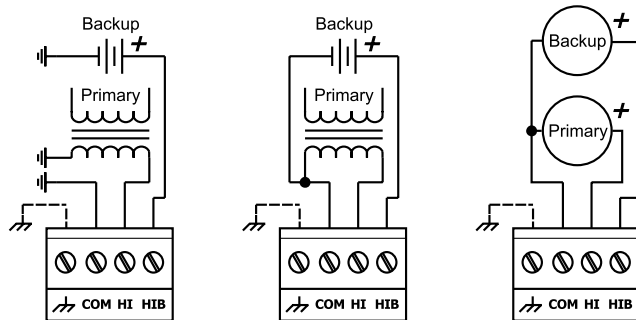

Typical Media Converter Installations

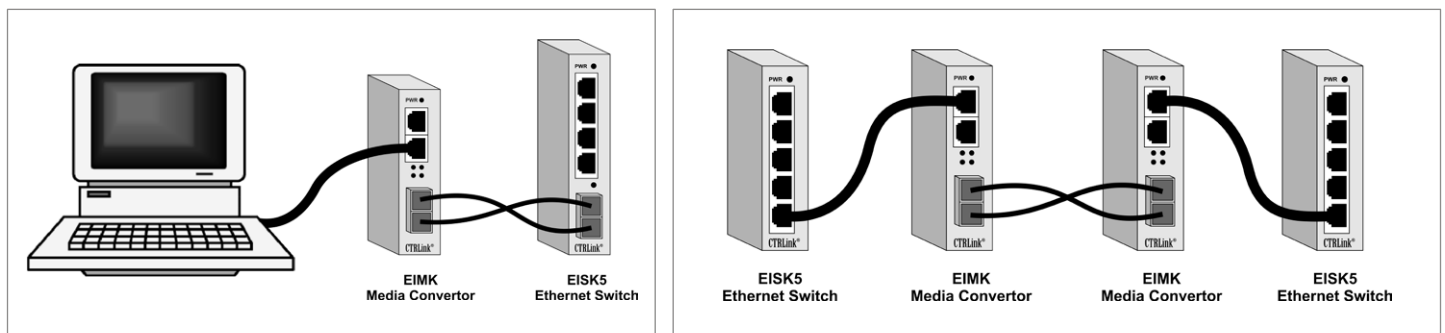

Ordering Information

Model	Description
EIMK-100T/FT	100BASE-TX/100BASE-FX (1300 nm) media converter w/ ST connectors (multimode)
EIMK-100T/FC	100BASE-TX/100BASE-FX (1300 nm) media converter w/ SC connectors (multimode)
EIMK-100T/FCS	100BASE-TX/100BASE-FX (1300 nm) media converter w/ SC connectors (single-mode)

United States

Contemporary Control Systems, Inc.
2431 Curtiss Street
Downers Grove, IL 60515
USA

Tel: +1 630 963 7070
Fax: +1 630 963 0109

info@ccontrols.com
www.ccontrols.com

China

Contemporary Controls (Suzhou) Co. Ltd
11 Huoju Road
Science & Technology Industrial Park
New District, Suzhou
PR China 215009

Tel: +86 512 68095866
Fax: +86 512 68093760

info@ccontrols.com.cn
www.ccontrols.asia

United Kingdom

Contemporary Controls Ltd
Sovereign Court Two
University of Warwick
Science Park
Sir William Lyons Road
Coventry CV4 7EZ
United Kingdom

Tel: +44 (0)24 7641 3786
Fax: +44 (0)24 7641 3923

info@ccontrols.co.uk
www.ccontrols.eu

Germany

Contemporary Controls GmbH
Fuggerstraße 1 B
04158 Leipzig
Germany

Tel: +49 341 520359 0
Fax: +49 341 520359 16

info@ccontrols.de
www.ccontrols.eu